

Implantation suivant A
 Implantation according to A
 Ansicht nach A

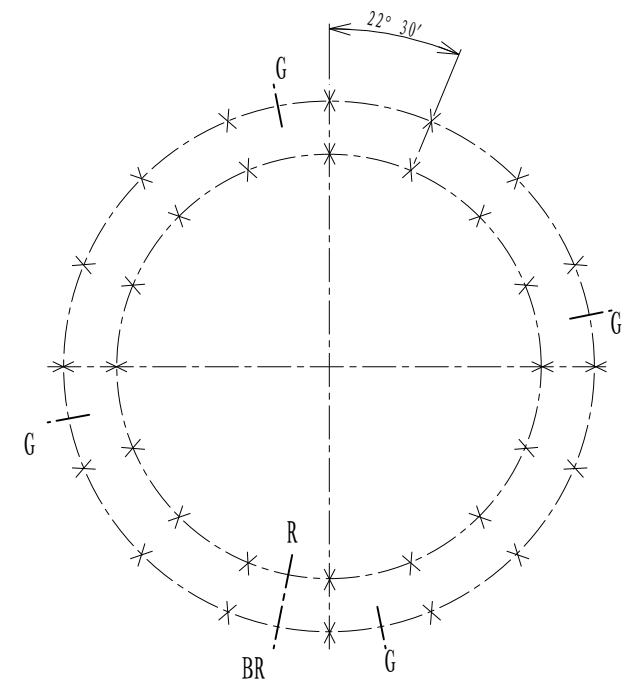

Denture - Gear - Verzahnung	
Module	Angle de pression
Module - Modul	Pressure angle
Diametral pitch	Eingriffswinkel
Nbre de dents	Troncature - Kopfkürzung
Nr. of teeth - Zahnezahl	
Diamètre primitif	
Pitch diameter - Teilkreissdurchmesser	
Déport 2 m d	
Add. mod. 2 m d - Profilschiebung 2 m d	
Cote sur dents	
Measurement on teeth	
Zahnmessweite bei Zähnen	
Faux rond au diamètre primitif - Run out on P.D. Rundlauffehler am Teilkreis	
Non trempée No hardened Ungehärtet	Trempée Hardened Gehärtet

Tolérances générales suivant IT-ETR-061 General tolerances according to IT-ETR-061 Allgemeine Toleranzen nach IT-ETR-061					
X	B. E. Q. R. A. R.	16	Trous de fixation Mounting holes Befestigungsboreungen	φ 18	equiv. equiv.
	B. I. I. R.	16	Trous de fixation Mounting holes Befestigungsboreungen	φ 18	gl. Abst. equiv.
G	B. E. Q. R. A. R.	4	Trous de graisseurs Grease holes Schmierbohrungen	M 10 x 1.00	gl. Abst. equiv.
	B. I. I. R.		Trous de graisseurs Grease holes Schmierbohrungen		gl. Abst. equiv.
B	Position approximative du bouchon et du raccord de trempé Filler plug and hardening connection of raceway				
R	ca Stopfen - und heerteschlupf - position				

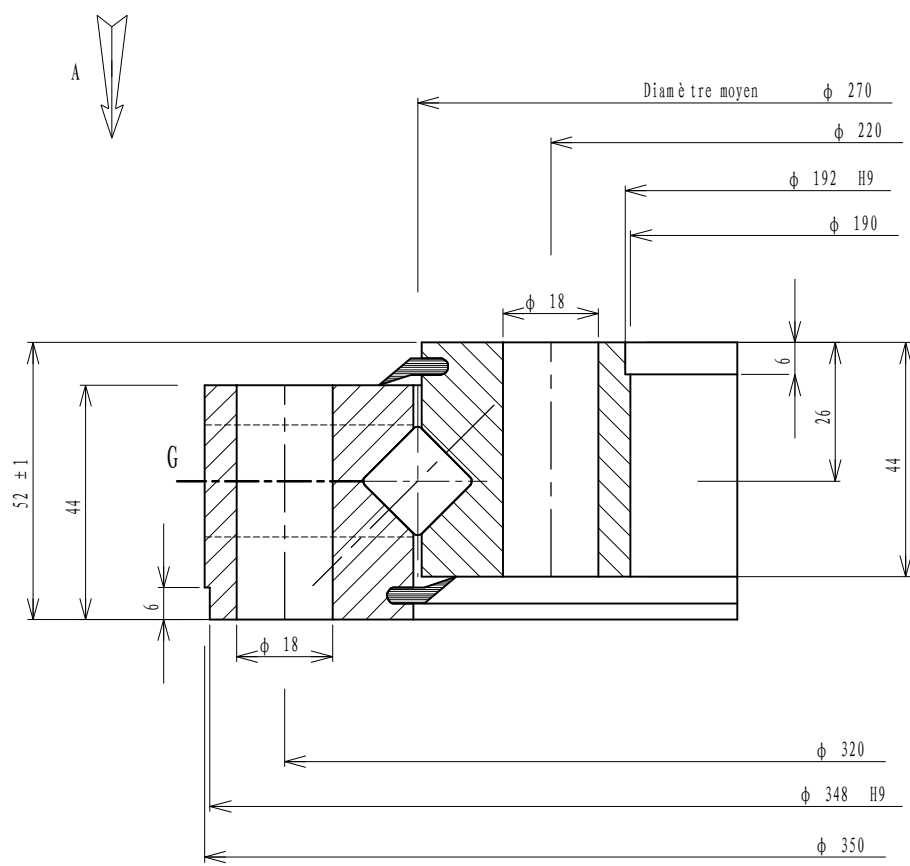
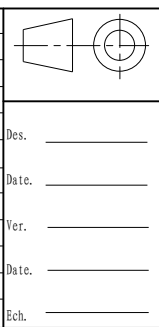

Masse estimée Gewicht ca Estimated weight	21	kg lbs
Des.		
Date.		
Ver.		
Date.		
Ech.		

N° 08-0270-04
 Indice A
 Luoyang Jiecheng Bearing Technology Co., Ltd
 Add: D1805, No. 3 Lianmeng road,
 Luoyang, Henan, China. Postal: 471003
 Phone: +86-379-68611678
 Fa x: +86-379-68611679
 E-mail: sales@jcb-bearing.com